



reximex



ACCURA

PCP AIRGUN OWNERS MANUAL

.177 Cal. - .22 Cal. - .25 Cal

**READ ALL INSTRUCTIONS AND WARNINGS
IN THIS MANUAL BEFORE USING THIS AIRGUN**



INDEX



reximex

<u>Page</u>	<u>Content</u>
1	Warranty
1	Warning
2	Safety Review
3	General Instructions & Operating Safety
3	Manual Safety
4	Operating Instructions
4	A. Filling The Air Cylinder
5	B. Loading The Airgun
7	C. Un-Loading & Un-Cocking The Airgun
8	D. Power Adjustment
8	E. Jammed Ammo
9	F. Trigger Adjustment
9	G. Butt-Pad Adjustment
10	H. Maintenance
11-14	Mechanism Parts & Part Numbers

1. WARRANTY

All REXIMEX PCP Airguns carry a One Year Warranty against faulty workmanship and defective materials. Contact the dealer from which you purchased the airgun if it becomes necessary. If the airgun develops a defect within the warranty period, contact the dealer from whom it was purchased. The guarantee does not cover any damage caused by tampering with the airgun.

2. WARNING!

WARNING! NOT A TOY. THIS AIRGUN IS RECOMMENDED FOR ADULT USE ONLY. MISUSE OR CARELESS USE MAY CAUSE SERIOUS INJURY OR DEATH. MAY BE DANGEROUS UP TO 800 YARDS (732 METERS).

WARNING! DO NOT BRANDISH OR DISPLAY THIS AIRGUN IN PUBLIC. IT MAY CONFUSE PEOPLE AND MAY BE A CRIME.

DO NOT CHANGE THE COLORATION AND MARKINGS TO MAKE IT LOOK MORE LIKE A FIREARM. POLICE AND OTHERS MAY THINK IT IS A FIREARM AND IT MAY BE A CRIME.

YOU AND OTHERS NEXT TO YOU SHOULD ALWAYS WEAR SHOOTING GLASSES TO PROTECT YOUR EYES.

BUYERS AND USERS HAVE TO OBEY THE LAWS ABOUT THE USE AND OWNERSHIP OF THIS AIRGUN

WARNING! NEVER ATTEMPT TO DISASSEMBLE THIS AIRGUN WHILE IT IS CHARGED!
FAILURE TO OBEY THIS INSTRUCTION COULD RESULT IN PERSONAL INJURY OR DAMAGE TO THE AIRGUN!

3 SAFETY REVIEW

- Never use the airgun if you are intoxicated or under the influence of drugs.
- Even if there is no pressure sign on the manometer, never disassemble the pressurized tube!
- Never fire the airgun when it is empty of air or when the air cylinder is removed!
- Never point the airgun at anyone, or allow anyone to point an airgun at you!
- Treat every airgun as if it is loaded even if you know it is not loaded!
- Always carry the airgun so that the direction of the muzzle is under control, even if you stumble.
- Always be sure of your target and what lies behind it before firing your airgun.
- Never leave a loaded airgun unattended.
- Beware of targets that tend to cause ricochets.
- It is recommended that eye protection is worn when charging the air cylinder.
- Always use caution when operating this airgun.
- Only use dry cloth to clean any dirt inside the barrel for various reasons (humidity, dust, etc.)
- In your airgun, only use synthetic or mineral base high viscosity oil in order not to create filling effect with lower tolerance parts.
- Learn and obey the laws in your location.
- Be responsible in your use of this weapon!

REXIMEX PCP airguns are designed specifically for use with DRY COMPRESSED AIR. NO OTHER GAS OR GAS COMBINATION CAN BE USED.

The Airgun may be filled by a Diving Scuba Tank or a suitable compressor
MAXIMUM SAFE WORKING PRESSURE (SWP): 250 BAR



DANGER OF EXPLOSION!

THE AIR TANK POSES THE EXPLOSION RISK IF IT GETS HEATED SUBJECT TO SUNRAY FOR EXTENDED PERIOD OF TIME.

(Max. +40° / Min. -05°)

OTHERWISE, THE AIRGUN SHOULD BE LEFT TO COOL DOWN IN A COOL ENVIRONMENT RECOMMENDED TO BE TRANSPORTED UNDER MAXIMUM 80 BARS PRESSURE DURING FLIGHTS.

4 GENERAL INSTRUCTIONS & OPERATING SAFETY

- REXIMEX Airgun should be fitted with a scope or alternate optic sights before use.
- Before using your airgun, read and abide by the basic safety rules.

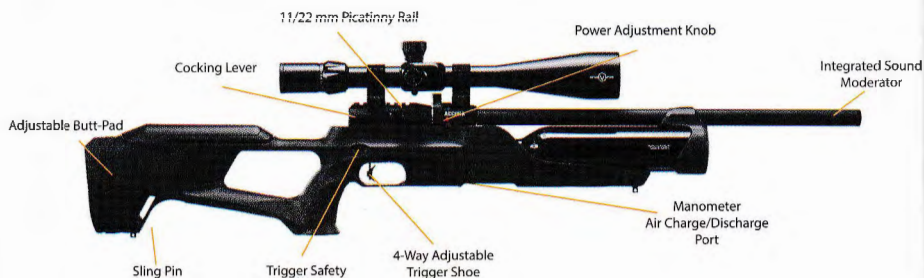

MANUAL SAFETY

CAUTION: Like all mechanical devices, airgun safety can fail. Even when the safety is on "SAFE" you should continue to handle the airgun in a safe manner.

Locate the safety switch of the airgun directly above the trigger guard. Safety switch can be set to "S" (SAFE) and "F" (FIRE) positions manually.

The Letters "S" (SAFE) and "F" (FIRE) are located below the safety switch.

A - Airgun on "S" (SAFE) Position

To set the safety on, push the safety switch from the left side of the airgun. In this position the trigger cannot be pulled and the airgun cannot be fired.



B - Airgun on "F" (FIRE) Position

To set the safety off, push the safety switch from the right side of the airgun. In this position the trigger can be pulled and the airgun can be fired.

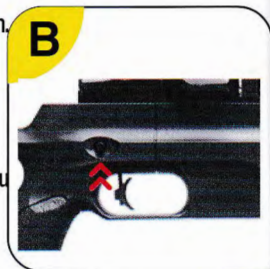

WARNING! KEEP THE AIRGUN IN THE "SAFE" POSITION UNTIL YOU ARE READY TO SHOOT. WHEN READY PUSH THE SAFETY SWITCH TO "FIRE" POSITION

5 OPERATING INSTRUCTIONS

A. FILLING THE AIR CYLINDER

Warning!

1. Before filling the air cylinder; make sure the airgun is on "S" (SAFE) position, no pellets are loaded in the air airgun and/or barrel and magazine is not mounted in the gun.

NOTE: If the air cylinder pressure is at "0" Bar, then it will be necessary to cock the airgun to remove the force of the Hammer against the firing Valve. Otherwise, the air will pass through the firing Valve out the barrel, and the air cylinder will not pressurize.

2. Take all safety measures before filling the air cylinder. It is compulsory for the user and to wear eye & ear protection when filling the air cylinder.

3. While filling in the air cylinder; the pressure in the air cylinder must be monitored from the air gauge of the hand pump or scuba charging kit. Do not look at the air gauge on the air cylinder during filling process. Instead, reference the gauge on your fill device.

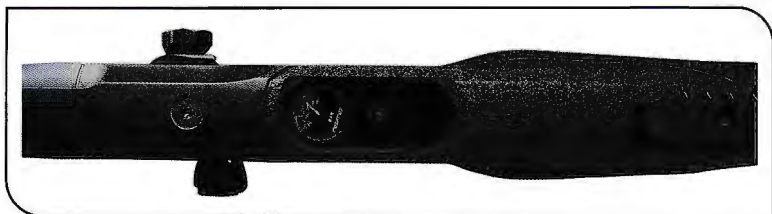

Assemble the filling equipment hose with the filling probe that is provided inside the box. Pull back on the outer sleeve on the quick connect fitting to release it from your airgun, when your tube is filled. If you hear SOUND of air during the first filling, move the probe and enable the O rings to be air-proof. (if the leakage continues, O rings might be deformed)

Overfill

In case of overfilling, SAFETY BURST DISC is located on your airgun. This disc will tear if the air pressure on your airgun reaches to a dangerous level and this will prevent any potential over pressure danger.

In case the safety burst disc is torn, a spare burst disc is included in your box and it needs to be changed.

B. LOADING THE AIRGUN

CAUTION: Never re-use ammunition.

Review the entire manual, including the section on Safety, before firing your airgun.

CAUTION: Know your airgun's loading mechanism for safest use! Pellets can either be loaded one by one using a single shot tray, or multiple pellets may be loaded using the rotary magazine. With the magazine placed correctly, EVERY action of closing the side lever WILL place a pellet into the chamber.

DO NOT TRY TO CLOSE THE SIDE LEVER WHEN THE MAGAZINE IS NOT LOADED!!!

Do not re-cock the airgun while there is pellet loaded inside the chamber!! This will load multiple pellets at the same time and may damage your airgun.

Removal of the magazine WILL still leave the chambered pellet in place unless the airgun is fired.

Loading the Magazine

Make sure your airgun is on "SAFE" position and is pointed to a SAFE DIRECTION.

If the magazine is fitted on the airgun, remove it to begin loading or Unloading.

Move the clear cover over the catch point and rotate in the direction of the arrows (clockwise) Fig. A. Place a finger under the magazine covering the hole, place the first pellet in the magazine nose first, make sure that the pellet does not protrude out of the magazine. If the pellet does protrude, simply push the pellet inward. Fig. B

Rotate the cover counterclockwise and place the remaining pellets into the magazine. Upon completion rotate the cover until it comes to rest. Fig. C

If it looks like Fig. D. The magazine is now ready for use.

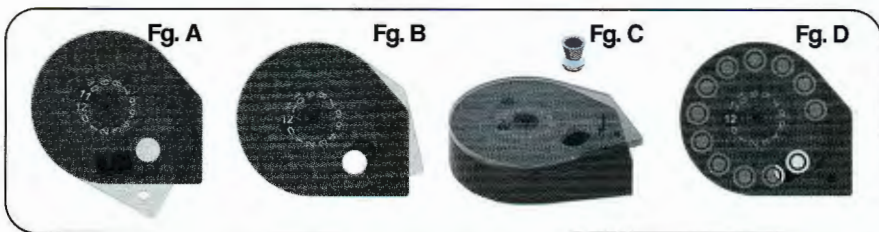

Placing the loaded Magazine on the Airgun & Firing Safely

NOTE: Following these directions will load your airgun and it will be ready to FIRE. Make sure your airgun is on "SAFE" position and is pointed to a SAFE DIRECTION.

- To fit the magazine into the airgun, pull the cocking handle backwards until it stops.
- With the cover of the magazine facing the butt of the airgun, insert the magazine from the right side and push it inward until it snaps into place.
- The line on the back of the magazine should align with the line on the loading slot of the airgun.

YOU WILL DAMAGE THE MAGAZINE IF IT IS NOT PLACED CORRECTLY

- Pull the cocking handle to its rear-most position.
- Push the cocking handle forward fully and ensure that it lays flat against the airgun in order to chamber a pellet.
- After following these steps and reading the entire manual, including the section of safety procedures, your airgun is now loaded and ready to fire.

DO NOT CLOSE THE COCKING HANDLE / MAGAZINE RELEASE BOLT UNTIL YOU ARE READY TO FIRE.

- Aim at your intended target and disengage the safety and prepare to shoot.
- Pull the trigger gently and the airgun will fire.
- To reload airgun, pull the cocking handle to its rear-most position. This will index the magazine and align the next pellet with the barrel. Then, repeat previous steps.

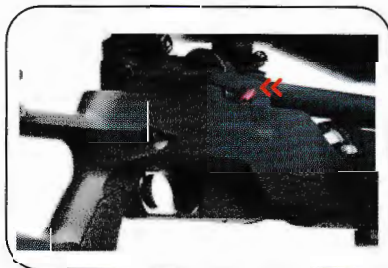

C. UN-LOADING & UN-COCKING THE AIRGUN

Un-loading & Removing the Magazine

1. Pulling the cocking handle to its rear-most position and Pushing it forward fully while the magazine is loaded will result in chambering a pellet.
2. To unload the airgun, it is recommended to fire the pellet in a SAFE DIRECTION.
3. Pull the side lever back to the rear position.

CAUTION: This action WILL cock the airgun.

4. Push the magazine out of the receiver from the left side.
5. Un-cock the airgun for safe storage.

Un-Cocking

When you are finished shooting, remove the magazine as instructed and un-cock the airgun by following the steps below:

1. Point the airgun in a SAFE DIRECTION.
2. Take the airgun on "FIRE" position.
3. Pull the cocking handle back to its rear-most position.
4. While firmly holding the cocking handle in the rear position, pull the trigger.
5. Continue to hold the trigger back while sliding the side lever forward to the latched position.
6. Release the trigger.
7. Put the airgun on "SAFE" position.

WARNING! EVEN THOUGH YOU FOLLOW THE UNLOADING PROCEDURE, CONTINUE TO TREAT THE AIRGUN AS IT IS LOADED. NEVER POINT THE AIRGUN AT ANYTHING YOU DO NOT INTEND TO SHOOT.

D. POWER ADJUSTMENT

Simply rotate the power switch while the airgun is un-cocked in the "+" or "-" direction and set the desired power level.

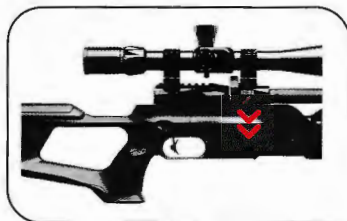
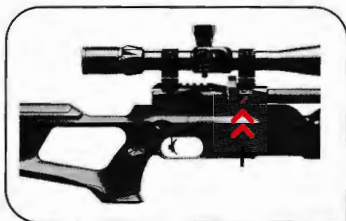

E. JAMMED AMMO

A jammed ammo is usually caused by firing the airgun when the air pressure is too low. Please, do not operate your airgun below 100 bar (1500 PSI) air pressure.

CAUTION: Never try to look through the barrel to see if a jammed ammo is cleared.

Make sure the airgun is on "SAFE" position and pointed in a SAFE DIRECTION.

- Pull the cocking handle back to its rear-most position.
- Insert a clearing rod of the proper size into the barrel, starting from the muzzle (Barrel may be damaged if the clearing rod is not proper size)

NOTE: Cocking handle must be at its rear-most position for the jammed ammo to clear the breech when it is pushed out by the ramrod.

- Push or tap ammo towards the breech end of the barrel until the pellet is extracted from the chamber.
- Operate carefully in order not to damage the chamber sealing O-ring.
- Remove and discard the ammo.
- Do not reuse that ammo.

If you are not successful removing the jammed ammo following above instructions, take no further action. REXIMEX Technical Service or an Authorized Service Station will unjam your airgun (Free of charge during the warranty period).

F. TRIGGER ADJUSTMENT

- First, remove the grip area using an Allen wrench. (Bottom of the grip)
- After removing the grip area successfully, trigger sensitivity adjustment may be done using an Allen wrench as shown on the picture.
- Re-mount the grip using the Allen wrench.

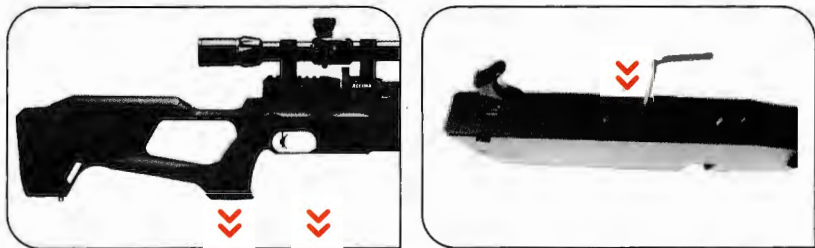

G. BUTT-PAD & CHEEK PIECE ADJUSTMENT

- Adjust up and down with the help of the buttons on the side of the pad and cheek piece.
- Adjust back and forth with the help of Allen wrench.

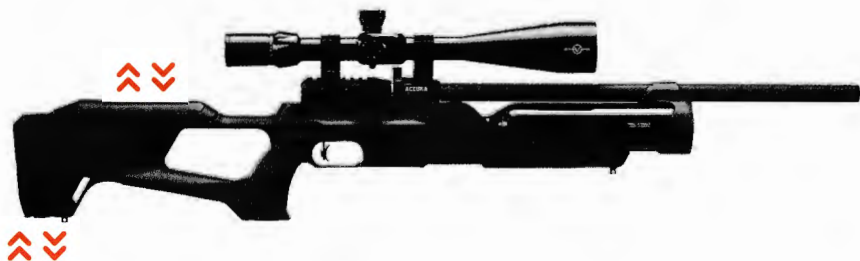

WARNING! DO NOT MODIFY OR ALTER YOUR AIRGUN. ATTEMPTS TO MODIFY THE AIRGUN IN ANY WAY INCONSISTENT WITH THIS MANUAL MAY MAKE YOUR AIRGUN UNSAFE TO USE, CAUSE SERIOUS INJURY OR DEATH, AND WILL MAKE THE WARRANTY INACTIVE.

WARNING! DO NOT ATTEMPT TO REPAIR YOUR AIRGUN OR TO DISASSEMBLE TO CORRECT AN OVER-FILL OR VALVE LOCK. PARTS MAY FLY OUT FROM THE AIRGUN AT DANGEROUS SPEEDS IF IT IS DISASSEMBLED WHILE PRESSURIZED.

H. MAINTENANCE

- Apply Reximex silicone chamber oil on the barrel breech and O-rings every 3 months or 500 shots.
- Periodically check your airgun. If anything feels different, like a shorter or weaker trigger pull, this may mean worn out or broken parts, call Reximex customer service for assistance before re-using your airgun.

REPLACEMENT OF O-RINGS

After a period of time, the O-rings on the fill probe will need to be replaced. The need for this will become noticeable if air is heard leaking from the nozzle while charging the airgun.

LUBRICANT

General: Keep the airgun clean and wipe it off with regular gun oil and a cloth occasionally.

Fill probe: Apply a thin layer of suitable mineral based oil occasionally or when dried out.

Magazines: Apply a thin layer of suitable mineral based oil occasionally or when dried out.

Cocking handle and Sidelever Sliding Surface: Apply a thin layer of a standard multipurpose grease occasionally or when dried out.

WARNING: Never use grease or spray oil in the moving parts inside the gun. This can result in unstable power and also leakage. Be moderate with lubricant.

I. STORAGE

Store in a place that is dry and dark. Store with air pressure between 50-200 bar in the airgun.

WARNING!

- Keep away from spaces with high humidity as steel parts might corrode.
- Keep away from bright sunlight as this shortens the life of the O-rings.
- Never store the airgun loaded with pellets.

Please Visit www.reximex.com for more information & “How to?” videos.

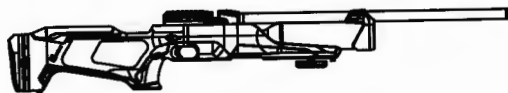

NO	Code	Name
1	ACC - 1-0-0	Air Bottle Sub Assembly
2	ACC - 2-0-0	Chassis Sub Assembly
3	ACC - 3-0-0	Barrell Sub Assembly
4	ACC - 4-0-0	Stock Group Sub Assembly

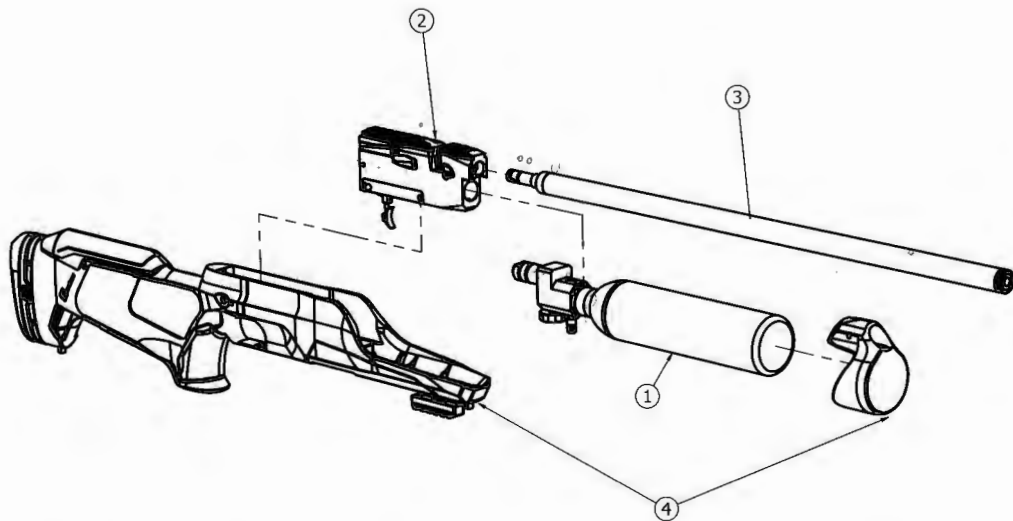

ACC - 1-0-0 - Air Bottle Sub-Assembly

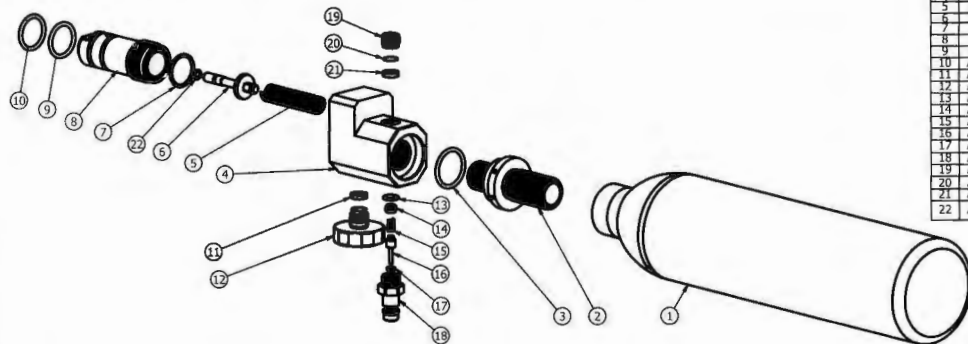

NO	Code	Name
1	ACC - 1-1-1	Air Bottle
2	ACC - 1-1-2	Air Bottle Adapter
3	ACC - 1-1-3	O-Ring 19x2
4	ACC - 1-1-4	Spring
5	ACC - 1-1-5	Air Bottle Valve Spring
6	ACC - 1-1-6	Air Bottle Valve
7	ACC - 1-1-7	O-Ring 16x1.5
8	ACC - 1-1-8	Valve Housing
9	ACC - 1-1-9	O-Ring 16-4x2
10	ACC - 1-1-10	O-Ring 16-4x2
11	ACC - 1-1-11	Pressure Gauge Pad
12	ACC - 1-1-12	Pressure Gauge
13	ACC - 1-1-13	O-Ring 6x1.5
14	ACC - 1-1-14	Filling Port Screw
15	ACC - 1-1-15	Filling Port Spring
16	ACC - 1-1-16	Filling Port Valve
17	ACC - 1-1-17	O-Ring 2x1.5
18	ACC - 1-1-18	Filling Port
19	ACC - 1-1-19	Safety Screw
20	ACC - 1-1-20	Burst Disk
21	ACC - 1-1-21	Safety Disk Pad
22	ACC - 1-1-23	O-Ring 3.5x1

ACC - 3-0-0 - Barrell Sub-Assembly

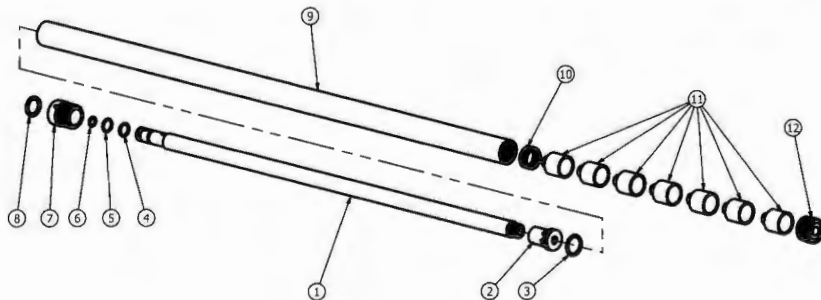

NO	Code	Name
1	ACC - 3-1-1	Barrell
2	ACC - 3-1-2	Moderator Tip
3	ACC - 3-1-3	O-Ring 15x2
4	ACC - 3-1-4	O-Ring 9x1.5
5	ACC - 3-1-5	O-Ring 9x1.5
6	ACC - 3-1-6	O-Ring 6x1.5
7	ACC - 3-1-7	Barrell Casing Adapter
8	ACC - 3-1-8	O-Ring 13x2.5
9	ACC - 3-1-9	Barrell Casing
10	ACC - 3-1-10	Moderator Spring
11	ACC - 3-1-11	Moderator Baffles
12	ACC - 3-1-12	Barrell Casing Cap

NO	Code	Name
1	ACC - 2-1-1	Chassis Top Cover
2	ACC - 2-1-2	Socket Head Countersunk Screw M3x10
3	ACC - 2-1-3	Socket Head Countersunk Screw M3x10
4	ACC - 2-1-4	Socket Head Countersunk Screw M3x10
5	ACC - 2-1-5	Cocking Lever Counter Pin
6	ACC - 2-1-6	Cocking Lever Counter Spring
7	ACC - 2-1-7	Cocking Lever Counter Screw
8	ACC - 2-1-8	Parallel Pin 2x20
9	ACC - 2-1-9	Parallel Pin 2x12
10	ACC - 2-1-10	Parallel Pin 2x12
11	ACC - 2-1-11	SetScrew M5x8
12	ACC - 2-1-12	SetScrew M5x8
13	ACC - 2-1-13	Cocking Lever
14	ACC - 2-1-14	Ball Bearing 3x7x3
15	ACC - 2-1-15	Cocking Lever Rear Screw
16	ACC - 2-1-16	Cocking Lever Linkage
17	ACC - 2-1-17	Ball Bearing 3x7x3
18	ACC - 2-1-18	Pellet Pusher
19	ACC - 2-1-19	Cocking Lever Front Pin
20	ACC - 2-1-20	Hammer Carrier Screw
21	ACC - 2-1-21	Hammer Carrier Wedge Screw
22	ACC - 2-1-22	Magazine Stopper Ball SetScrew
23	ACC - 2-1-23	SetScrew M3x8
24	ACC - 2-1-24	Parallel Pin 2.5x6
25	ACC - 2-1-25	Hammer Spring Base
26	ACC - 2-1-26	Hammer Tension Adjustment Screw
27	ACC - 2-1-27	Hammer Spring Washer
28	ACC - 2-1-28	Imbus Screw M4x8
29	ACC - 2-1-29	Hammer Spring
30	ACC - 2-1-30	Hammer
31	ACC - 2-1-31	SetScrew M4x4
32	ACC - 2-1-32	Safety Spring
33	ACC - 2-1-33	Safety Catch Pin
34	ACC - 2-1-34	Safety Switch
35	ACC - 2-1-35	SetScrew M5x8
36	ACC - 2-1-36	SetScrew M5x8
37	ACC - 2-1-37	O-Ring 3x1.5
38	ACC - 2-1-38	O-Ring 3x1.5
39	ACC - 2-1-39	Parallel Pin 2.5x8
40	ACC - 2-1-40	Power Adjustment Valve
41	ACC - 2-1-41	Parallel Pin 3x24
42	ACC - 2-1-42	Trigger Mechanism Spring
43	ACC - 2-1-43	Rear Trigger
44	ACC - 2-1-44	Trigger Mechanism Spring
45	ACC - 2-1-45	Hammer Holder
46	ACC - 2-1-46	Rear Trigger Lever
47	ACC - 2-1-47	Hammer Holder Sear
48	ACC - 2-1-48	Trigger Mechanism Spring
49	ACC - 2-1-49	SetScrew M3x8
50	ACC - 2-1-50	Trigger Finger Rest Pin
51	ACC - 2-1-51	SetScrew M3x2
52	ACC - 2-1-52	Trigger Finger Rest
53	ACC - 2-1-53	Parallel Pin 3x20
54	ACC - 2-1-54	Parallel Pin 3x20
55	ACC - 2-1-55	Parallel Pin 3x20
56	ACC - 2-1-56	Parallel Pin 3x20
57	ACC - 2-1-57	Socket Head Countersunk Screw M3x8
58	ACC - 2-1-58	Safety Switch Cap
59	ACC - 2-1-59	Chassis Slide Cover
60	ACC - 2-1-60	Socket Head Countersunk Screw M3x8
61	ACC - 2-1-61	Chassis

ACC - 2-0-0 - Chassis Sub-Assembly

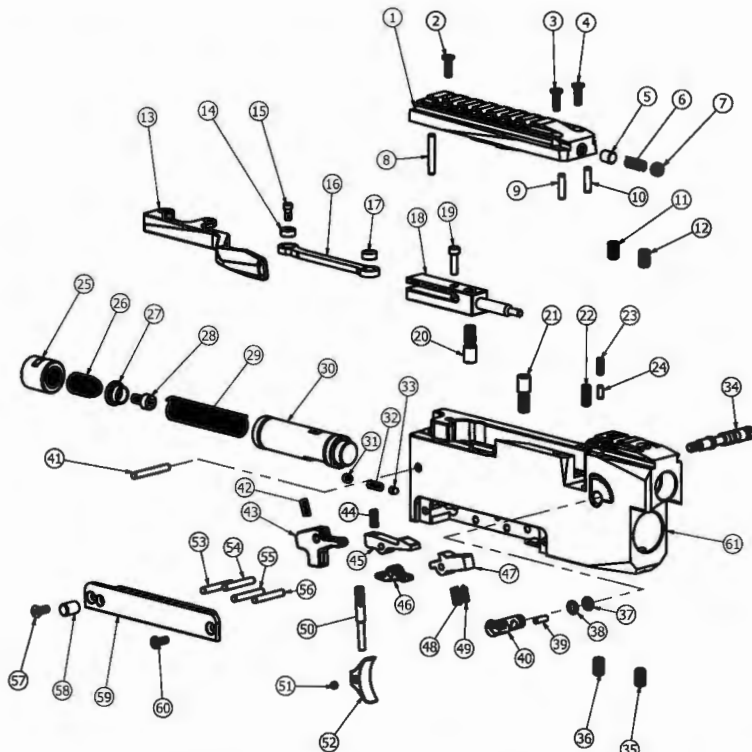

ACC - 4-0-0 - Stock Sub-Assembly

NO	Code	Name
1	ACC - 4-1-1	Stock Shoulder Rest
2	ACC - 4-1-2	SetScrew M5x8
3	ACC - 4-1-3	Stock Inner Structure Anchor
4	ACC - 4-1-4	Stock Inner Structure
5	ACC - 4-1-5	Cheek Rest
6	ACC - 4-1-6	Cheek Rest Mast
7	ACC - 4-1-7	Stock
8	ACC - 4-1-8	Pan Head Cross Screw M4x8
9	ACC - 4-1-9	Sling Attachment Screw
10	ACC - 4-1-10	Pan Head Cross Screw M4x8
11	ACC - 4-1-11	Pan Head Cross Screw M4x8
12	ACC - 4-1-12	Protective Plastic Washer
13	ACC - 4-1-13	Socket Head Countersunk Screw M6x50
14	ACC - 4-1-14	Picatinny Anchor
15	ACC - 4-1-15	Imbus Screw M6x10
16	ACC - 4-1-16	Lower Picatinny
17	ACC - 4-1-17	Sling Attachment Screw
18	ACC - 4-1-0	Air Bottle Hat

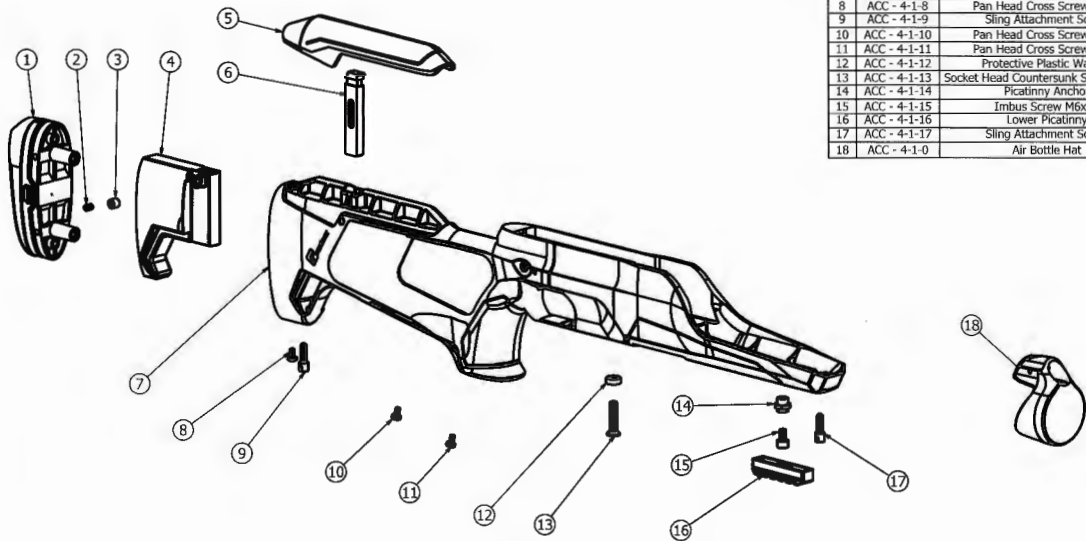

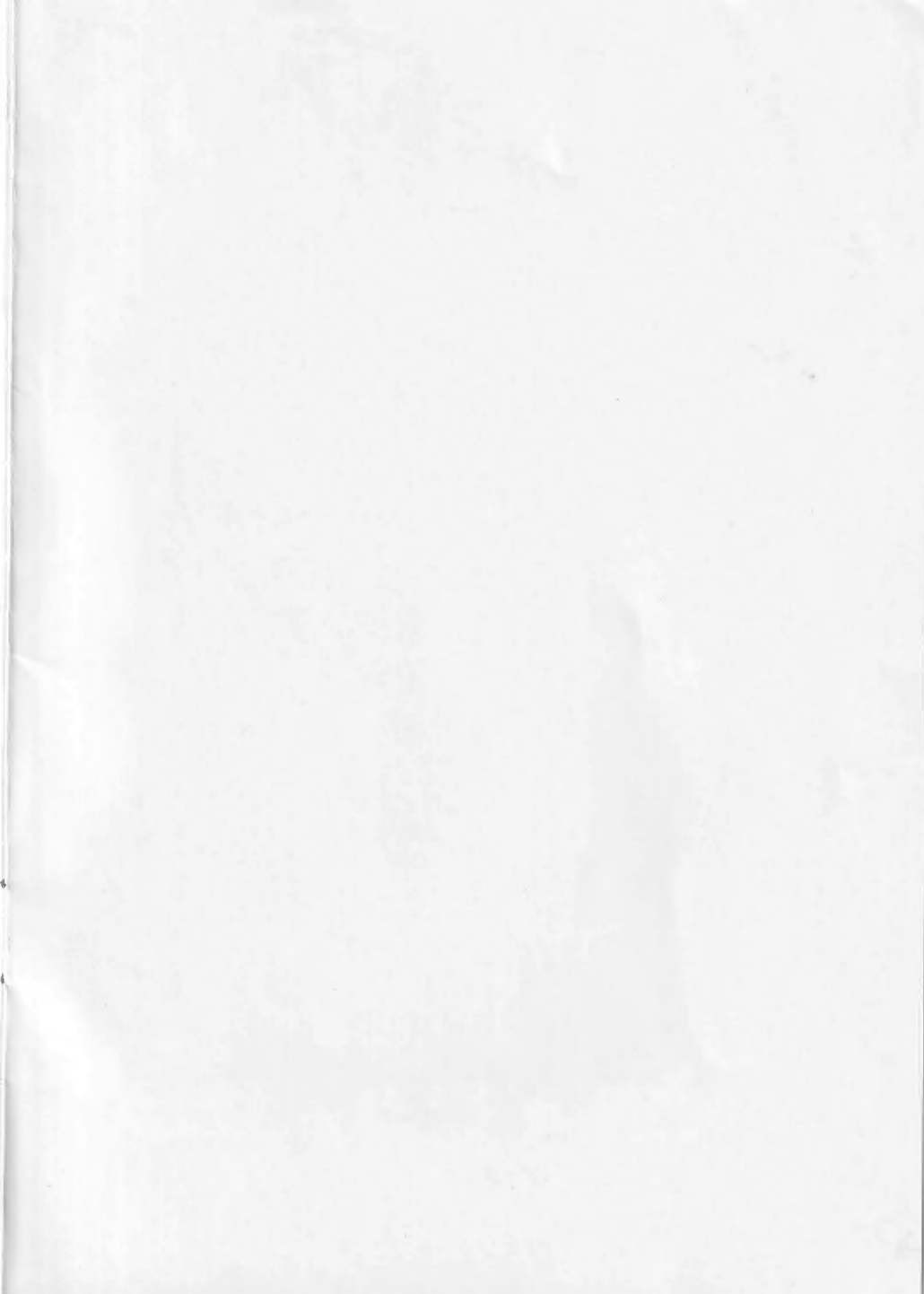



reximex



REXIMEX İt. İh. Av Malz. Sav. San. Tic. Ltd. Şti.



Bayavşar Mahallesi 41958. Sokak No:3 Beyşehir / Konya



0332 511 0055



info@reximex.com



www.reximex.com



/Reximexarms



/Reximexarms



/Reximexarms