

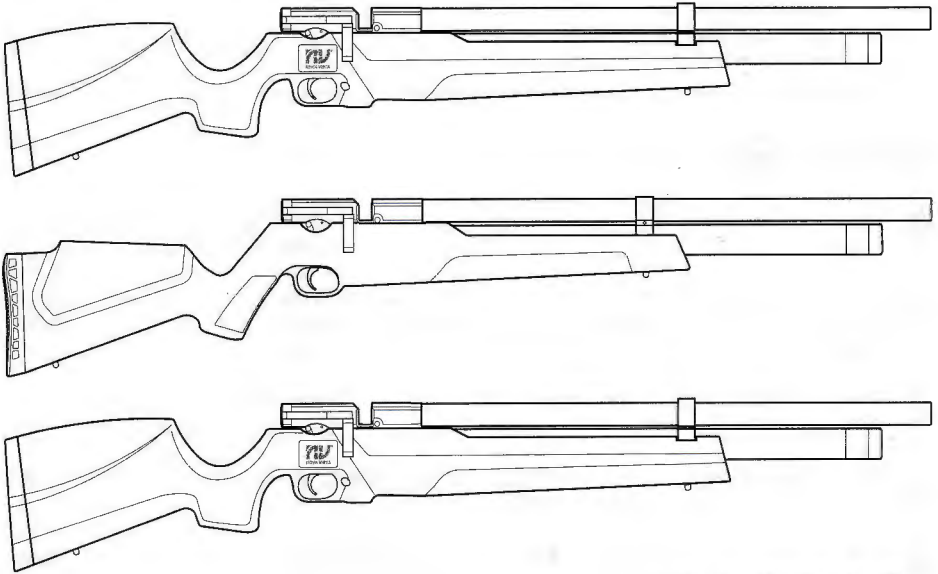

Sythetic Black  
Synthetic Camo  
Wood  
Laminate



# ALPHA PCP AIR RIFLE



**PRE CHARGED PNEUMATIC**

PCP AIR RIFLE

## OPERATION MANUAL

PLEASE READ ALL INSTRUCTIONS AND WARNINGS IN THIS MANUAL BEFORE USING THIS AIR RIFLE

RETAIN FOR FUTURE REFERENCE











EN

PLEASE READ ALL INSTRUCTIONS AND WARNINGS IN THIS MANUAL BEFORE USING THIS AIR RIFLE



This safety alert symbol indicates important safety messages throughout this Operation Manual. When you see this symbol, be alert with warnings to the possibility of personal injury and carefully read the message that follows to avoid risks of serious injury or death.

## WARNING INSTRUCTIONS

-  This is not a toy. This air rifle is recommended for adult use only. Misuse or careless use may cause serious injury or death. May be dangerous up to 1,000 yards (914 Meters).
-  Do not brandish or display this air rifle in public. Police and others may think it is a firearm. Do not change the coloration or markings to make it look more like a firearm. This is dangerous and may be a crime.
-  This product contains one or more chemicals known to cause cancer and birth defects or other reproductive harm.
-  Use only compressed air in this air rifle. Do not use other gasses, including oxygen, which can cause a fire or explosion that may result in serious injuries or death.
-  This air rifle has been classified as an adult air rifle, and is recommended for adult use only. Because it is considered to be a special purpose air rifle, it is exempt from specific types of trigger pull, safety, mechanism and drop tests.
-  User is obliged to read the warnings and instructions in this manual carefully and understand the use of the air rifle and the legalization of the law.
-  This air rifle has an adjustable match grade trigger. It could fire when dropped or jarred even with or without the safety engaged.
-  Treat your air rifle as if it is always loaded and ready to fire. Always keep the muzzle pointed in a safe direction. Be aware of ricochet (bouncing off). Never shoot at hard surfaces or into water.
-  Do not disassemble or alter your air rifle. Repair should only be done by an authorized repair department. Otherwise you will void your warranty.
-  This air gun designed for use at pressures between 6.5MPa ~20MPa (65bar ~ 200bar /942psi ~ 2900psi). Maximum pressure of internal air reservoir is 20MPa (200bar / 2900psi). Do not fill the air rifle past the maximum pressure.

## SAFETY PRECAUTIONS

1. Users should always know that this air rifle is a dangerous product that can cause accident anytime.
2. User should always be aware of the risk of this air rifle and treat it with caution.
3. Store your air rifle on Safety "S" (SAFE) position and inaccessible to children or unauthorized persons.
4. Always remove the magazine and make sure there is no pellet in the chamber when not in use.
5. Always keep the muzzle pointed in a safe direction. Never point your air rifle at yourself or others.
6. Keep your trigger finger out of the trigger guard until you have decided to shoot.
7. Before leaving your air rifle unattended or to somebody else, put the safety on "S" (SAFE) position and unload.
8. Proper eye protection must always be worn for shooters and spectators. All spectators should remain behind the shooter.
9. Be certain the pellet use is appropriate for the caliber requirements. Check the marking on your air rifle to verify the pellet size.
10. Do not repeat loading. Only single pellet is allowed at a time.
11. Do not shoot at hard surfaces. This may cause bounce off or ricochet.
12. Be sure of your target and what is beyond the backstop. Always examine the backstop before shooting for wear or damage.
13. This air rifle is equipped with a 40MPa (400bar / 5800psi) automatic overpressure relief valve. It protects the other parts of the air rifle from damage. If damaged or stops functioning, please send to authorized maintenance department for new valve replacement.



**THIS IS A HIGH POWER AIR RIFLE RECOMMENDED FOR USE BY THOSE 18 YEARS OF AGE OR OLDER. READ ALL INSTRUCTIONS BEFORE USING. THE PURCHASER AND USER SHOULD CONFORM TO ALL LAWS GOVERNING USE AND OWNERSHIP OF AIR RIFLES.**

# 1. LEARNING THE PARTS OF YOUR AIR RIFLE

Familiarize yourself with name of parts to better understand this Operation Manual.

## ALPHA (Synthetic Black/Camo Stock)

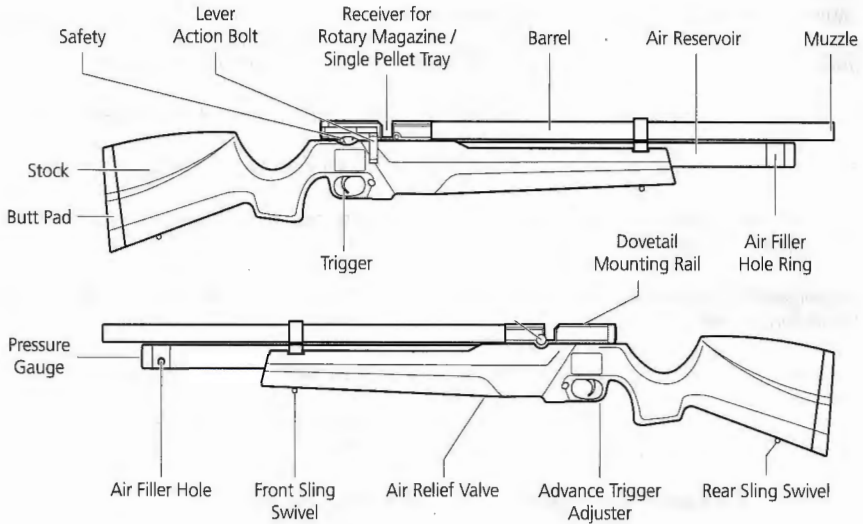

## ALPHA (Wood Stock)

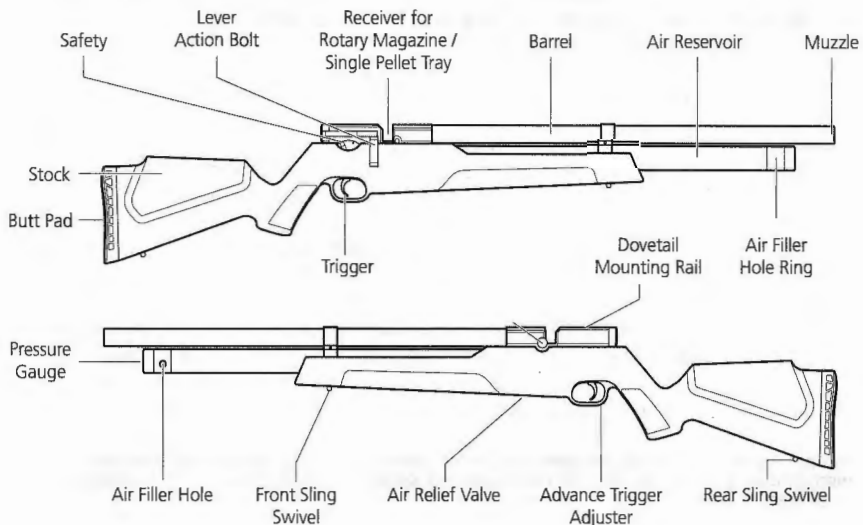

## 2. OPERATING THE SAFETY

1. The safety located above the trigger. It allows you to set this air rifle to "S" (SAFE) and "F" (FIRE) positions.
2. Setting "S" (SAFE) Position: Pull inwards and the safety should point to the "S" indicator, and at the same time safety cover the red dot. (Fig.2a)
3. Setting "F" (FIRE) Position: Push outwards and the safety should point to the "F" indicator, and at the same time shows the red dot signifying it is ready for shooting. (Fig.2b)
4. The safety is only allowed to point at "S" or "F" position. Do not position in the middle of "S" and "F". (Fig.2.c)

- ⚠ Always manually and visually keep air rifle in the "S" (SAFE) position until you are actually ready to shoot. Failure to follow these instructions may result in serious injuries or death.
- ⚠ Like all mechanical devices, an air rifle safety can fail. Even when the safety is set on "S" (SAFE) position, continue handling the air rifle safely. Never point the air rifle at any person and anything you do not intend to shoot.

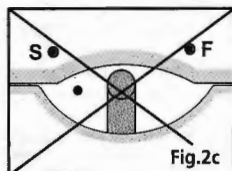
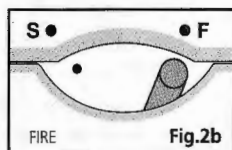
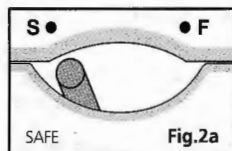

## 3. PRESSURIZING (FILLING) WITH COMPRESSED AIR

1. Make sure the air gun is unloaded, the Safety is on "S" (SAFE) position and keep the muzzle pointed in a safe direction. Be sure to wear eye protection.
2. Locate the filler hole ring on the reservoir and rotate a certain angle (Fig.3a). You will see the filler hole. (Fig.3b)
3. Insert the fill probe into the filler hole. (Fig.3c)
4. Connect the compressor and observe the reading on the pressure gauge.
5. Maximum air pressure shall not past 30MPa (300bar / 4350psi).
6. When pressurizing (filling) is completed, pull out the fill probe and rotate the filler hole ring and make sure the filler hole is covered and clear from dirt.

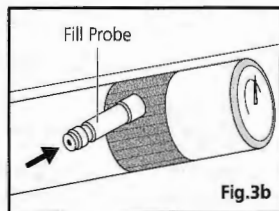
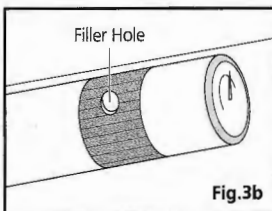
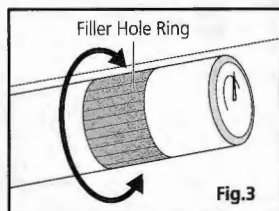

- ⚠ This air rifle uses only compressed air. Do not use other gases, including oxygen, which can cause explosions that may result in serious injuries or death.
- ⚠ When the fill probe is removed from the air rifle, it must be deflates so that there is no air in the hose. Otherwise, the hose will pop up and causing serious injuries or death.
- ⚠ The air should be pressurized slowly. Otherwise, heat is generated that affects the accuracy of the pressure. Overpressure can cause explosions, serious injuries or death.
- ⚠ This air gun designed for use at pressures between 6.5MPa ~ 20MPa (65bar ~ 200bar / 942psi ~ 2900psi). Maximum pressure of internal air reservoir is 20MPa (200bar / 2900psi). Do not fill the air rifle past the maximum pressure.

#### 4. DEPRESSURIZING (DEFLATE) THE AIR RIFLE

1. Like most PCP air gun, is best stored with some pressure in the reservoir. This keeps the seals in the air gun forced against the sealing surfaces. If your air gun is over fill you can depressurizing by using tool.
2. Make sure the air gun is unloaded, and the Safety is on "S" (SAFE) position and keep the muzzle pointed in a safe direction. Be sure to wear eye protection.
3. Use Word wrench slowly turn the air relief valve counter-clockwise, do not rotate more than 2 circles. (Fig.4a)
4. Do not remove the relief valve screw as the relief valve should remain with the stock.
5. After depressurizing the air, use the Word wrench to tighten the relief valve clockwise.
6. Check the pressure gauge to make certain all pressure has been relieved from this air rifle.

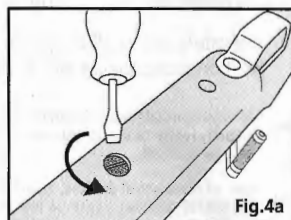

**⚠** Performing the above procedure will exhaust air from the barrel at a high rate and could discharge a pellet that is chambered. Always make certain this air rifle is pointed at a safe direction.

#### 5. TRIGGER

1. This trigger can be adjusted according to individual preference. It has been factory set to an efficient setting that will suit most hunting and target uses. It should not need to be modified. (Unless you are experienced in making such adjustments, otherwise it may result in serious injury. Please read the **Sec.17** (Advance Trigger Adjustment.)
2. Keep your trigger finger out of the trigger guard until you have decided to shoot.

#### 6. THE USE OF SINGLE PELLET TRAY

1. Make sure the Safety is on "S" (SAFE) position and keep the muzzle pointed in a safe direction.
2. Pull the bolt back to the cock position.
3. Fill the single pellet tray into the receiver. Press the bottom to a reliable position. Select the appropriate size of the pellet tray. (Fig.6a)
4. Push and pull the bolt and make sure the receiver locking pin moves forward and backward freely.
5. Lay a pellet of appropriate caliber in the pellet tray. (Fig.6b)
6. Push the bolt forward as far as possible. This chambers a pellet into the barrel and this air rifle is ready to fire. Be careful not to squeeze or damage the pellet as this could affect accuracy.

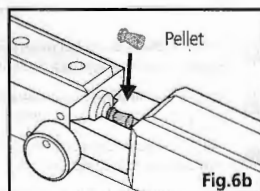
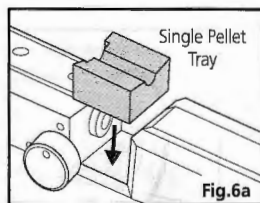

**⚠** Only allow one pellet each time. Do not repeat loading into the chamber, otherwise it may cause damage and may not fire.

## 7. LOADING THE ROTARY MAGAZINE

1. Lift the transparent cover along the direction of the arrow (clockwise) rotation until it stops. **(Fig.7a, Fig.7b)**
2. Place a finger under the magazine covering the hole.
3. Place the first pellet in the magazine, the tip of the pellet will be pointing out of the hole and the back of the pellet should now be seen thru the transparent cover. Make certain the pellet does not protrude out the back of the magazine. In the event the pellet does protrude simply push the pellet inward. Be careful not to squeeze or damage the pellet as this could affect accuracy. **(Fig.7c)**
4. Rotate the cover counter-clockwise and place the remaining pellets into the magazine. Lock the cover at the starting position and the magazine is now ready for use. **(Fig.7d)**

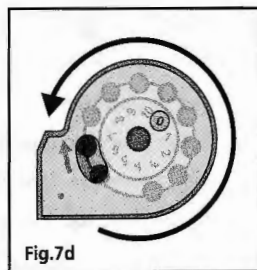
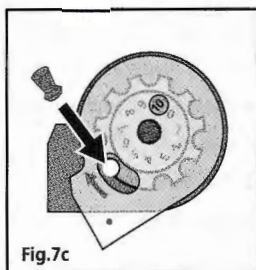
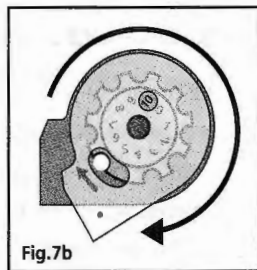
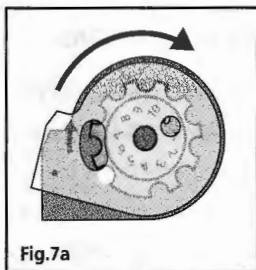

## 8. INSERTING THE ROTARY MAGAZINE

1. Make sure the Safety is on "S" (SAFE) position and keep the muzzle pointed in a safe direction.
2. Pull the bolt back to the cock position.
3. With the transparent cover of the magazine facing to the back of the air rifle, insert the magazine from the right side and push it inward until it snaps into place. **(Fig.8a)**
4. Push the bolt forward fully and latch to chamber a pellet.
5. This air rifle is now ready to fire.
6. Only one pellet should be pushed into chamber each time.
7. Do not repeat with the bolt loaded, this prevents more than one pellet feeding into the chamber.
8. This magazine is designed so it will stop reloading automatically when empty. Pull the bolt, and push the magazine out of the receiver from the left side. **(Fig.8b)**
9. Repeat the steps if you wish to continue shooting.

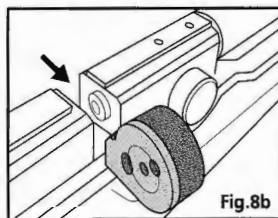
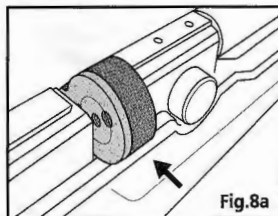

## 9. LOADING AND SHOOTING INSTRUCTIONS

1. Make sure the safety is on "S" (SAFE) position and keep the muzzle pointed in a safe direction. Check
2. the pressure gauge is within 6.5MPa ~ 20MPa (65bar ~ 200bar / 942psi ~ 2900psi). If the pressure is insufficient, it will be pressurized (please follow the instructions on **Sec.3**). If the pressure is overfill, the pressure will be relieved (please follow the instructions on **Sec.4**).
3. Adjust the power adjustment knob to your preference.
4. Assemble sight or scope.
5. Pull the bolt back to the cock position.
6. Place the single pellet tray or rotary magazine into the receiver, and make sure it is installed accurately.
7. Push the bolt forward fully and latch to chamber a pellet.
8. Push the safety outwards to point to "F" (FIRE).
9. Aim at target, pull the trigger and shoot.
10. Repeat steps above in reverse manner when not in use.



## ADVANCE SYSTEM TUNING

### 10. ADVANCE TRIGGER ADJUSTMENT

- ⚠ This air rifle is for adults. It has been factory set to an efficient setting that will suit most hunting and target uses. Therefore, advance calibration is not required.
- ⚠ Advance trigger adjustment can be adjusted if you are experienced in making such adjustments, otherwise it may result in serious injury or death. Read these instructions carefully.
- ⚠ Adjustment of the trigger screw could inhibit proper function of the safety. It may cause the safety to NOT point at "S" or "F" position. Always check for full engagement and smooth function of the safety upon completion of any changes to the trigger screw.
- ⚠ Adjustment to the trigger assembly could allow this air rifle to fire if dropped or jarred even with or without the safety engaged. This can cause serious injuries or death.
- ⚠ This is a fully adjustable two stage trigger system. The adjustment on the trigger pull and trigger position is correlated with each other so it should be adjusted repeatedly to the best state. Always ensure the safety of the reliability.

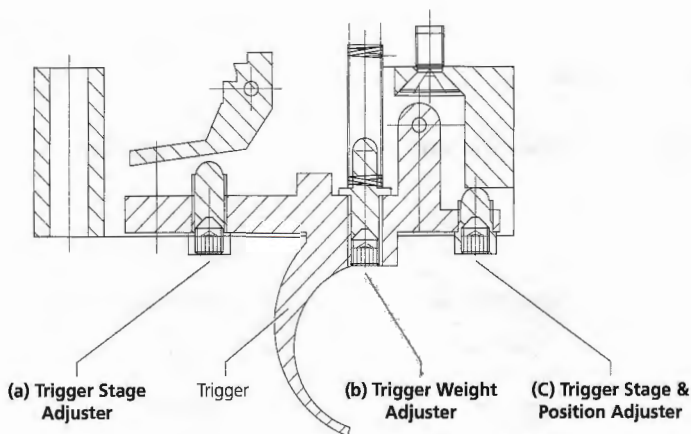

1. Make sure the Safety is on "S" (SAFE) position and keep the muzzle pointed in a safe direction.
2. Make sure the bolt is push forward and NOT cocking position.
3. Use Allen wrench provided in the packaging.
4. **(a) Trigger Stage Adjuster:** Use the Allen wrench and turn the adjuster screw clockwise to reduce the amount of first travel and turn counter-clockwise to increase the amount of first travel. These adjustments could affect the safety from NOT functioning properly, and therefore could allow the air rifle to fire when dropped or jarred.
5. **(b) Trigger Weight Adjuster :** Use the Allen wrench and turn the adjuster screw clockwise to increase trigger pull weight and counter-clockwise to decrease trigger pull weight.
6. **(c) Trigger Stage and Position Adjuster:** Changes can be made to the position and length of first and second stages of the trigger motion. Use the Allen wrench and turn the adjuster screw clockwise to reduce the amount of first travel and then move the trigger back. Turning counter-clockwise will increase the amount of first travel and move the trigger forward.

## 11. MAINTENANCE

1. Apply lubricants with a cotton swab on the barrel o-ring every 3 months or every 500 shots.
2. Apply lubricants to the sliding bolt mechanism every 3 months or every 500 shots.
3. Keep this air rifle clean and wipe with a cloth occasionally. It is recommended to clean the barrel with a dedicated method without damaging the barrel.
4. Suggest to store with pressure between 4MPa ~ 8MPa (40bar ~ 80bar / 580psi ~ 1160psi) in the air rifle. Store in a place that is dark. Keep away from high humidity and inaccessible to children.

**⚠** Do not introduce petroleum-based lubricants into the high-pressured reservoir, or it may cause an explosion. Failure to follow these instructions may result in serious injuries or death.

**⚠** Do not attempt to disassemble or repair this air rifle while it is filled with air pressure. Parts can fly from this air rifle at dangerous speeds and may cause serious injuries or death.

## 12. TROUBLE SHOOTING

PROBLEM	PROBABLE CAUSE	SOLUTION
Precision	Pellets	Try different pellets
	Magazine	Check magazine for malfunction, replace if needed
	Barrel breech o-ring	Check o-ring in barrel breech, replace if needed
	Low pressure	Contact your dealer, advance tuning if needed
Trigger won't engage	Worn trigger parts	Try adjusting, replace if needed
Air rifle won't fire	Low pressure	Contact your dealer, advance tuning if needed
	Empty of air	Charge the air rifle
	Worn parts	Contact your dealer, replacement if needed
	Jammed pellets	Removing jammed pellets
Safety won't work	Worn safety parts	Try adjusting, replace if needed

### 13. PRODUCT SPECIFICATIONS

MODEL	ALPHA	
DESCRIPTION	ALPHA PCP Air Rifle	
ACTION TYPE	Pre Charged Pneumatic	
STOCK	Synthetic Black / Camouflage / Wood / Laminate	
CALIBER	.177 (4.5mm)	.22 (5.5mm)
MUZZLE ENERGY	16J	
TRIGGER PULL	Adjustable	
AIR CAPACITY	190ml	
BARREL TYPE	Rifled Steel	
MOUNTING RAIL	Dovetail	
DIMENSIONS (L x W x H)	1100 x 62 x 200 mm	
WEIGHT	3 kg	

### 14. WARRANTY

1. This air rifle is warranted to the retail consumer for one year from date of retail purchase against defects in material and workmanship. Please contact your dealer for more information.
2. Warranty will be void if damages caused by abuse, modification or failure to perform normal maintenance.
3. This air rifle can only be repaired or disassemble by authorized repair department.

## LIMITED LIFETIME WARRANTY

Your air rifle and its accompanying accessories is warranted to be free of defects in materials and workmanship for the lifetime of the original owner. This warranty does not cover damages due to fair wear and tear, and failure to provide routine maintenance. This warranty lasts as long as the original purchaser owns the product, and is not transferable. In the event of a defect under this warranty, we will, at our discretion, repair or replace the product provided our inspection indicates that an original defect exists. Nova Vista reserves the right to replace any product which is no longer available with a product of comparable value and function. If Nova Vista determines the repair is not covered under the warranty guidelines, there may be a charge to you for the repair. This is a limited warranty and does not cover damages caused by misuse, modification, improper handling or installation or maintenance provided by someone other than a Nova Vista Authorized Service Center.

This limited warranty does not include consequential damages, incidental damages, or incidental expenses, including damage to property or any other expense. Nova Vista disclaims any implied warranties. Some states or countries do not allow the exclusion or limitation of incidental or consequential damages, or allow limitations on implied warranties so the above limitations or exclusions may not apply to you. This warranty gives you specific legal rights, and you may also have other rights which vary from state to state and country to country.

## WARRANTY CLAIMS & REPAIR SERVICES

If your air rifle or its accompanying accessory requires repair, contact Nova Vista Authorized Service Center or visit our website at [www.nova-vista.co/contact](http://www.nova-vista.co/contact). DO NOT ATTEMPT TO DISASSEMBLE. Any disassembly or modification not performed by a Nova Vista Authorized Service Center or our appointed qualified personnel will void the warranty.

Made in China

[www.nova-vista.co](http://www.nova-vista.co)

Information furnished by Nova Vista is believed to be accurate and reliable; however, no responsibility is assumed by Nova Vista for its use nor for any infringement of patents or other rights of third parties which may result from its use. Nova Vista reserves the right to change specifications at any time without notice.

**NOVA VISTA COMPANY LTD.**